

MODEL 310LXe

CAGE AND BOTTLE WASHER



Size:

Compartment:

48" wide x 32" high x 34" deep

Overall Unit:

72" wide x 82" high x 38½" deep

Note: Washer can be designed to any size to meet new or existing applications.

MODEL 310LXe

The LYNX Model 310LXe Cage and Bottle Washer is an electrically heated, heavy duty, single chamber, hydro-spray washer designed for thorough, efficient cleaning of cages, racks, debris pans, and miscellaneous items used in the care of laboratory animals.

STANDARD FEATURES:

- Vertical Sliding Door
- Oscillating Spray Jet System
- Personnel Safety Features
- Micro-computer Control System with Modem Package
- Automatic Ten-phase Treatment Cycle
- Automatic Self-cleaning Screen
- Temperature Guarantee
- Insulated Construction
- Incoming Utility Gauges
- Interior Illumination
- S/S Recirculation Piping and Components

CONSTRUCTION:

- All Stainless Steel Construction
- Automatic Water Level Control
- 7½ HP Treatment Pump
- Electric Heating Elements
- Touch Screen Operator Interface
- Programmable Cycles
- Direct Read Pump Pressure Gauge
- Double-pane Glass Window

ACCESSORIES:

- Stainless Steel Universal Cage Wash Rack System
- Stainless Steel Pan Wash Rack
- Transfer Cart
- Modular Walls
- Barrier Wall Flange(s)

300
SERIES

E1	Electrical	3-60-208/230/480 V	9 HP	
E2	Electrical	3-60-208/230/480 V	36 kW	
HW	Hot Water	1" NPT	35 PSI	30 GPM @ 140 °F ± 5 °F (20-140 gal/load consumption)
C	Condensate	1" NPT		
D	Drain	4" Floor Drain (Minimum)	90 GPM	Flow Rate @ 195 °F
V	Vent	8" ID Duct	200 CFM	Saturated Vapor @ 190 °F
A	Air	½" NPT	80 PSI	4 CFM Flow Rate
CW*	Cold Water	1" NPT	50 PSI	40 GPM @ 50 °F ± 5 °F

*CW – Required if drain discharge cool-down package is ordered

OPTIONAL FEATURES:

- LYNX OPTI-Wash™ System
- High Capacity Center Header System
- Pass-thru Unit
- Right or Left Hand Services
- Cold Water Fill
- Integral Data Collection System
- Air Compressor
- LYNX Smart-Cool™ System
- Automatic Damper
- Exhaust Fan
- Drain Discharge Cool-down
- Non-vented Vapor Condenser
- Pass-thru Door Interlock System
- Strip Chart Printer
- Seismic Tie Down
- Detergent Dispensing Systems
- pH Neutralization System
- pH Neutralization Monitoring System

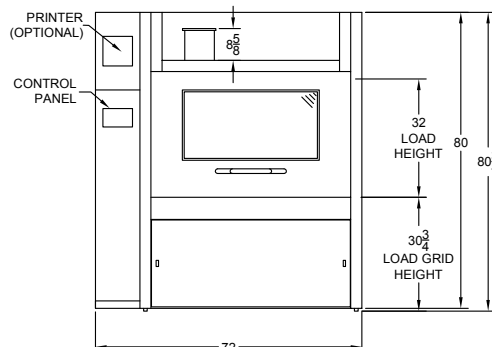
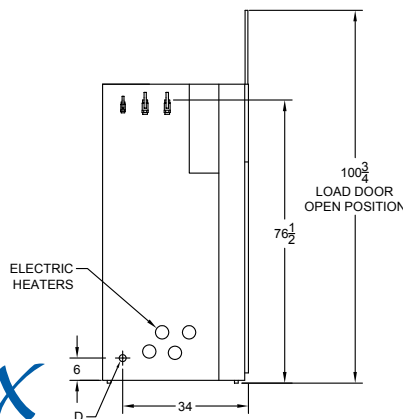
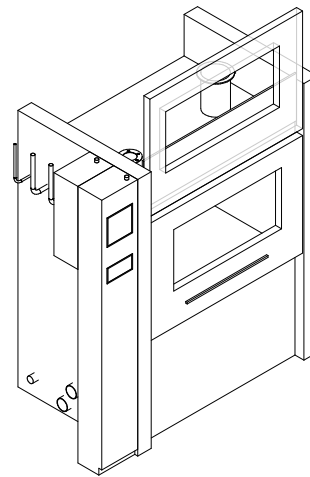
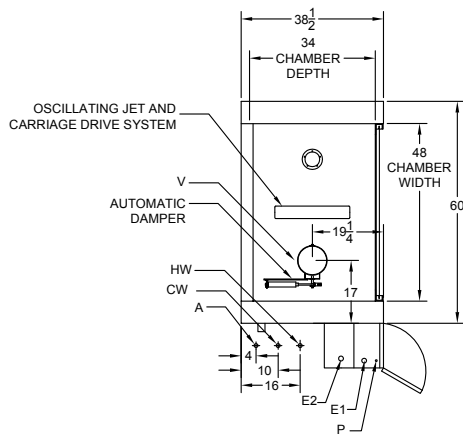

For further information, please contact: