



A Donald **BASIL** Company

Life Science Solutions

The LYNX mission is to provide Animal Care Washing Systems of the highest standards, quality, and reliability in the industry. Our service and customer care will be unmatched

Model 730LX Bedding Dispenser

APPLICATION:

The Bedding Dispenser is an automatic, conveyORIZED unit designed to automatically dispense most solid bedding materials into animal cages as they are conveyed through the filling chamber. The bedding volume dispensed into the cages is adjustable to accommodate various bedding depths and sizes of cages.

STANDARD FEATURES:

- All Stainless Steel Construction
- 12 Cubic Foot Bedding Hopper
- Powered Roller Conveyor
- Operator Control Panel
- Clean-out Access Ports
- Load End Water Collection Area

OPTIONAL FEATURES:

- Dust Collection System
- Knock Down Shipment
- Photo-electric Conveyor Stop
- Seismic Tie Down
- Discharge Roller Conveyor
 - 4'-0" long
 - 6'-0" long
 - 8'-0" long



SIZE:
Tunnel Opening: 12" high x 36" wide
Overall Size: 67" high x 80" wide x 96" long

Make a Difference...Make it LYNX!

Utilities: 730LX

E	Electrical	30A – 110V	
D	Drain	2" Floor Drain	
V	Vent	4" ID Duct	650 CFM

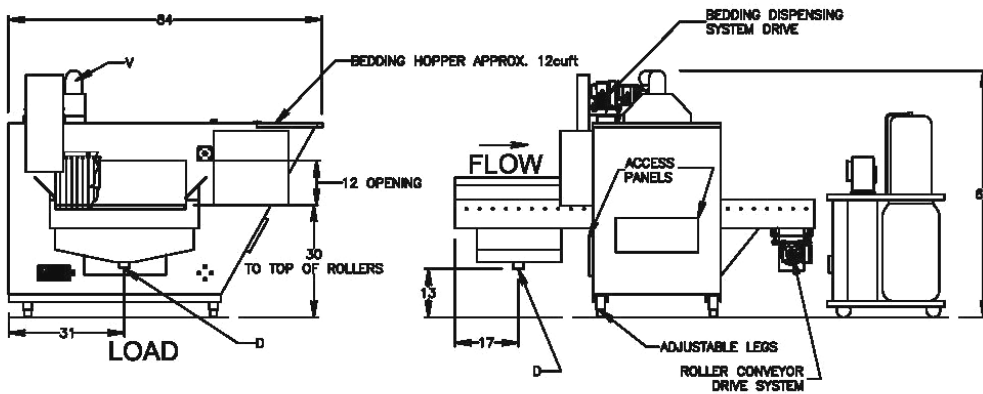
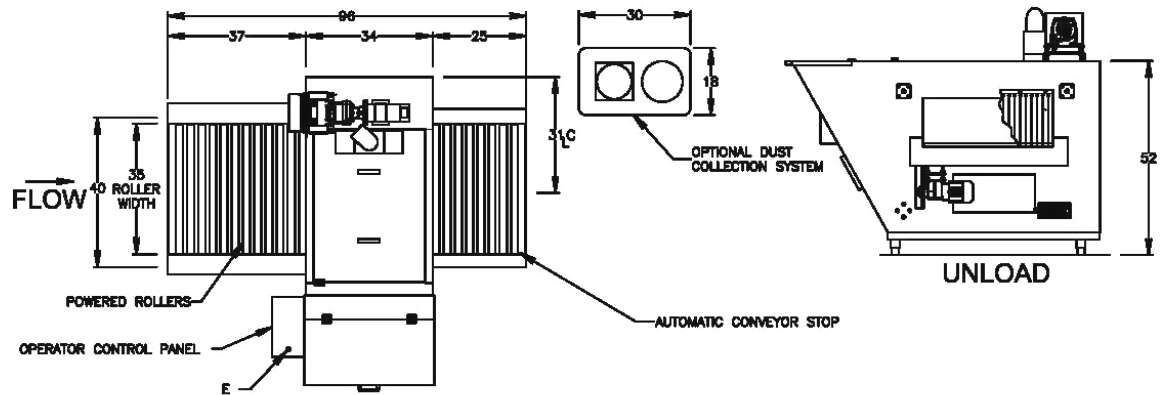

NOTE:

- The selection of certain options could reduce the above stated utilities. Please consult your LYNX representative to discuss your specific requirements.
- Drawing data is for general reference only. Each sized unit and selected options will effect the overall machine size. Obtain certified drawings for design and installation details.
- Specifications are subject to change without notice.